

# Primary Sabbath School Lessons

*THIRD YEAR, THIRD QUARTER*

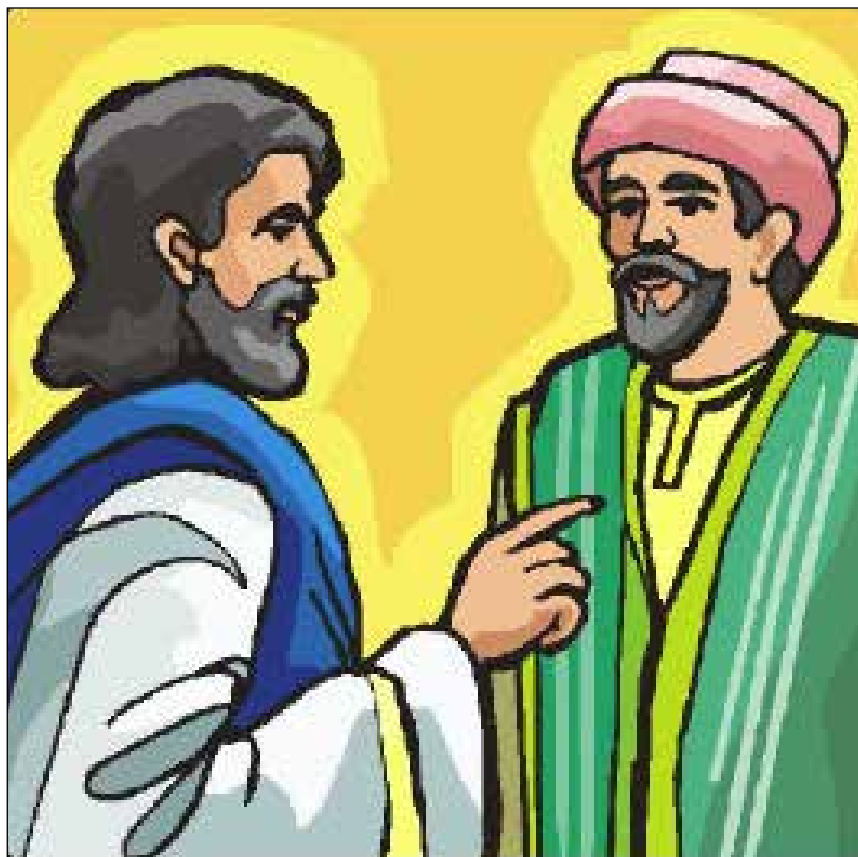

## ELIJAH AND ELISHA

**PRIMARY**  
**SABBATH SCHOOL LESSONS**

THIRD YEAR, THIRD QUARTER

ELIJAH AND ELISHA

© 2018 International Missionary Society, Seventh-day Adventist Church, Reform Movement, American Union. All rights reserved. No part of this publication may be edited, altered, modified, adapted, translated, reproduced, or published by any person or entity without prior written authorization from the International Missionary Society. Write to [info@sda1888.org](mailto:info@sda1888.org) for authorization.

Bible story illustrations used by permission.  
Copyright © Sweet Publishing/FreeBibleimages.org  
Copyright © Arabs for Christ  
Copyright © Richard Gunther

RELIGIOUS LIBERTY PUBLISHING ASSN.  
9999 East Mississippi Avenue  
Denver, CO 80247  
[info@sda1888.org](mailto:info@sda1888.org) / [www.sda1888.org](http://www.sda1888.org)

---

# Contents

---

## **ELIJAH AND ELISHA**

1. ELIJAH, GOD'S PROPHET . . . . .	5
2. GOD TAKES CARE OF ELIJAH. . . . .	7
3. THE WIDOW OF ZARAPHATH . . . . .	9
4. ELIJAH'S PRAYER. . . . .	11
5. THE GREAT TEST . . . . .	13
6. WICKED JEZEBEL . . . . .	15
7. ELIJAH AND ELISHA. . . . .	17
8. ELISHA THE PROPHET. . . . .	19
9. ELISHA AND THE BAD BOYS . . . . .	22
10. THE WOMAN OF SHUNEM . . . . .	25
11. NAAMAN'S SICKNESS. . . . .	28
12. MIRACLE OF THE AXEHEAD . . . . .	30
13. ELISHA AND KING JOASH. . . . .	32

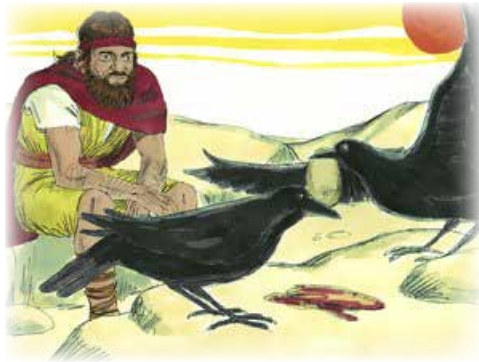

The story of Elijah the prophet and the promise that he made to King Ahab comes from what Moses said would happen if the people of Israel failed to "hearken unto the voice of the Lord thy God, to observe to do all His commandments and His statutes which I command thee this day;..." "Thy heaven that is over thy head shall be brass, and the earth that is under thee shall be iron." Deuteronomy 28:15, 23.



## Lesson 1

# ELIJAH, GOD'S PROPHET

**READING ASSIGNMENT: 1 KINGS 16:30-33 ; 17:1.**

**MEMORY VERSE:** *"The Lord is my rock, and my fortress, and my deliverer; my God, my strength, in whom I will trust,..." Psalm 18:2.*

Elijah was born in the land of Gilead, east of the Jordan River. The name "Elijah" means "my God is Jehovah." God spoke to Elijah and told him to go to Ahab, who was the king of Israel at that time.



**CIRCLE THE LETTER OF THE CORRECT ANSWER FOR EACH QUESTION.**

### 1. What message did Elijah give to Ahab?

- a. Many blessings would come.
- b. No rain would fall until Elijah would say so.
- c. Ahab would be known as a good king.

### 2. Why was this going to happen?

- a. Because of sin.
- b. Because Elijah did not like Ahab.
- c. Because God was angry.

It was not a happy message that Elijah was sent to deliver; but he did it willingly, because he loved God. And, just as he said, the dry weather began. The ground was so dry and hard that it was difficult to plow and even more difficult to plant crops. When it was time for the crops to come up, they did not appear. The level of the water in the streams and rivers got lower and lower. Pretty soon the cattle began to die, as well as the sheep and goats. The people began to worry and started to pray.

### **3. Did the people turn to God?**

### **4. To whom did they pray?**

- a. Elijah
- b. Ahab
- c. Idols

After it had not rained for a long time, and no dew had fallen, Ahab put a price on Elijah's head; a reward was offered to anyone who would find him. Ahab thought it was Elijah's fault that there had been no rain. But the king could not find Elijah.

### **5. Where do you think Elijah was?**

God knew where he was. God was protecting Elijah from any harm, because he had been so faithful in doing what he was asked. God will never forsake those who love the truth and willingly obey Him.

### **TRUE OR FALSE?**

**6. It did not rain, because Elijah was angry with Ahab. T/F**

**7. Ahab was a good king. T/F**

**8. The people prayed to idols instead of to God. T/F**

**9. Ahab wanted to kill Elijah. T/F**

**10. God knew where Elijah was, but others could not find him. T/F**



## Lesson 2

# GOD TAKES CARE OF ELIJAH

**READING ASSIGNMENT: 1 KINGS 17:2-7.**

**MEMORY VERSE:** *“Casting all your care upon Him; for He careth for you.” 1 Peter 5:7.*

The message Elijah was sent to deliver to King Ahab was not a pleasing one. When Elijah left Ahab's palace, he was told by God to go and hide near a brook.

 **CIRCLE THE LETTER OF THE CORRECT ANSWER FOR EACH QUESTION.**

### 1. What was the name of the brook?

- a. Cherith
- b. Jordan
- c. Sunny Brook

Elijah went there as God had directed. He was also told that his food would be provided and that he would not have to worry about it.

### 2. Who would feed Elijah?

- a. Angels
- b. Good people
- c. Ravens (birds)

When Elijah was hungry and no food could be found, a raven flew overhead and dropped something on the ground. It was food! Elijah was very thankful. More ravens came with food, and Elijah remembered God's promise.

**3. How often did Elijah receive food in this way every day?**

- a. Morning and evening.
- b. Three times a day.
- c. At lunchtime.

One day followed another, and still there was no rain. Elijah soon began to realize that the brook was drying up. As he thought about it, God told him to go to a town called Zaraphath. There God would sustain him.

**4. Whom did God prepare to help Elijah?**

- a. King Ahab.
- b. A widow.
- c. More ravens.

**5. What was the name of the town where the widow lived?**

- a. Israel
- b. Jerusalem
- c. Zaraphath



**HELP THE RAVENS FIND ELIJAH!**

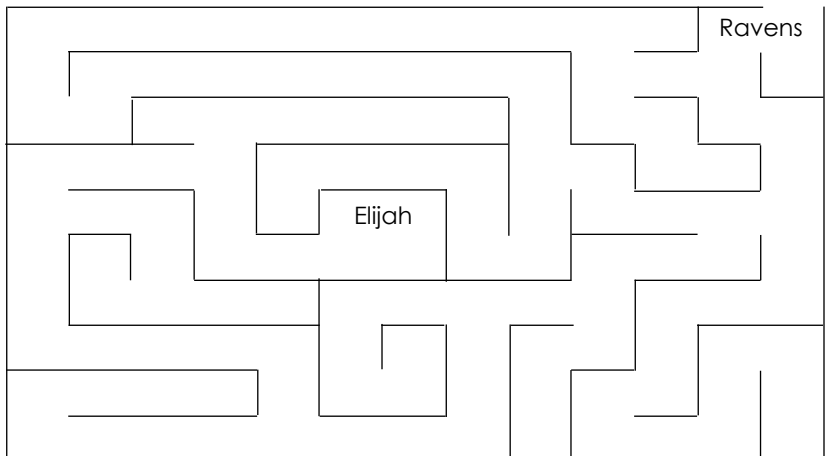

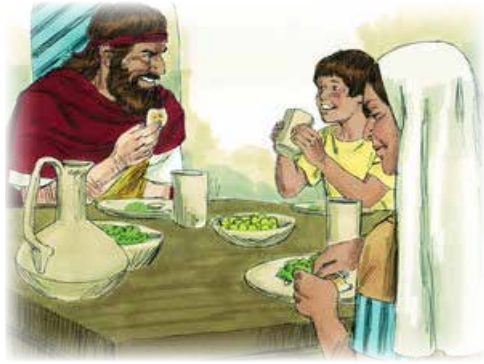

## Lesson 3

# THE WIDOW OF ZARAPHATH

### READING ASSIGNMENT: 1 KINGS 17:8-16.

**MEMORY VERSE:** *"I will abundantly bless her provision: I will satisfy her poor with bread." Psalm 132:15.*

When Elijah arrived in Zaraphath, he saw a woman gathering sticks to build a fire. He asked her to fetch him some water to drink. She did this. But then Elijah asked for food, and the widow did not know what to do.

### CIRCLE THE LETTER OF THE CORRECT ANSWER.

#### 1. What did the widow tell Elijah?

- a. I have only a little food.
- b. I'll get it right away.
- c. Go some place else.

The widow had only enough meal and oil to bake a little bread for herself and her son. She expected that after using what she had there would be no more to eat and she and her son would die.

### TRUE OR FALSE?

- 2. Elijah made a promise to her. T/F
- 3. He promised her that, if she would share her oil and meal now, it would last until the Lord again sent rain on the earth. T/F

#### 4. Did the widow do as Elijah asked?

The widow took the little bit of oil and meal, mixed it together, and made a cake for Elijah. She knew that after that there would be nothing left for her son or herself. The widow must have been a very kind person to share her only food with a stranger.



#### **TRUE OR FALSE?**

#### 5. The widow and her son died because there was no food. T/F

After making the food for Elijah, the widow looked into her container of oil and barrel of meal and was surprised to find that the oil and meal were still enough to make another loaf for herself and her son; and this is how it was every day until the famine ended. She trusted the promise of God's prophet and was blessed to survive that terrible time.



#### **MAKE A LIST BELOW OF A FEW OF YOUR BLESSINGS, AND TELL HOW YOU CAN SHARE THEM WITH OTHERS.**



## Lesson 4

# ELIJAH'S PRAYER

### READING ASSIGNMENT: 1 KINGS 17:17-24.

**MEMORY VERSE:** *“Now by this I know that thou art a man of God, and that the word of the Lord in thy mouth is truth.” 1 Kings 17:24.*

The widow was very kind to Elijah. She fixed a nice room for him upstairs and fixed his meals for him. As we already learned, she never lacked for food. One day a terrible thing happened in the widow's household.

### CIRCLE THE LETTER OF THE CORRECT ANSWER FOR EACH QUESTION.

#### 1. What happened to the widow's son?

- a. He went out to play.
- b. He got sick.
- c. He ran away from home.

The little boy was so sick that he died. His mother was very, very sad. She did not know what to do, so she went to Elijah. She told him that her little boy had died. Elijah was sad also.

#### 2. What did Elijah do?

- a. He took the boy upstairs.
- b. He said he was sorry but that he could not help.
- c. He left for another town.

Elijah laid the boy on the bed and prayed to God.



**FILL IN THE BLANKS.**

3. "O Lord my \_\_\_\_\_, I \_\_\_\_\_ Thee, let this child's \_\_\_\_\_ come into him again." 1 Kings 17:21.

**4. How many times did Elijah stretch himself over the little boy?**

- a. 100
- b. 3
- c. None

God answered Elijah's prayer and returned life to the boy. Elijah rejoiced and was very happy. He took the boy downstairs to his mother. Can you imagine how she felt when she saw her son alive once more?

**5. Did the mother thank Elijah?**

The little boy's mother was so happy and grateful to Elijah and to God! She said to Elijah, "By this I know that thou art a man of God, and that the word of the Lord in thy mouth is truth."



**DRAW A PICTURE BELOW OF THE LITTLE BOY ON THE BED AND ELIJAH PRAYING OVER HIM.**

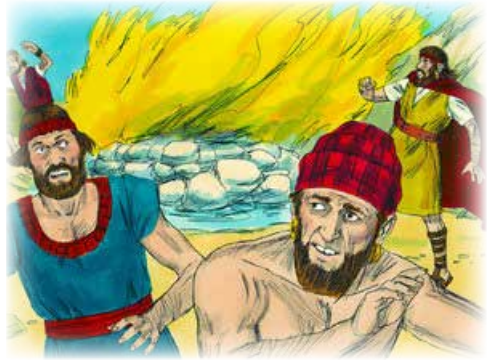

## Lesson 5

# THE GREAT TEST

### READING ASSIGNMENT: 1 KINGS 18.

**MEMORY VERSE:** *"The Lord, He is the God; the Lord, He is the God!"*  
1 Kings 18:39.

Three years passed, and no rain fell anywhere in Israel. At last the word of the Lord came to Elijah.

 **CIRCLE THE LETTER OF THE CORRECT ANSWER FOR EACH QUESTION.**

### 1. To whom was Elijah sent?

- a. Judah
- b. The widow
- c. King Ahab

On the way to King Ahab's palace, Elijah met Obadiah, who was the governor of Ahab's house. Obadiah was one of the few leaders who stayed faithful to God during this time.

### 2. What did Elijah tell Obadiah to do?

- a. Stay with him.
- b. Tell Ahab that he had found Elijah.
- c. Leave the country.

Obadiah was afraid that Elijah would disappear again. Then he would be killed by Ahab for letting Elijah get away. But Elijah promised that he would see Ahab that same day and that he would not go away.



**UNSCRAMBLE THE WORDS BELOW TO FIND THE ANSWER.**

**3. When Ahab came to Elijah, what did he ask him?**

Israel he art troubleth thou that?

Elijah replied that the people had brought the trouble upon themselves, because they had turned from God and followed Baal. He told Ahab to gather the 450 prophets of Baal on Mount Carmel. On that day, Elijah would prove who the true God was.



**CIRCLE THE LETTER OF THE CORRECT ANSWER.**

**4. How many different altars were there on Mount Carmel?**

- a. 2
- b. 1
- c. 3

One altar was for a sacrifice to Baal, and the other one was for the Lord. The priests of Baal were to go first. They put wood and a bullock on their altar. The prophets of Baal prayed all day, but nothing happened. At the time of the evening sacrifice, Elijah repaired the altar of the Lord, dug a large ditch around it, and poured water over the altar and the bullock—so much that the ditch was filled with water! How could a fire start when everything was all wet? This was a real test. Then Elijah prayed.

**5. Did God hear Elijah's prayer?**

Fire flashed down from heaven and consumed the offering, the wood, the stone altar itself, and the water in the ditch. All the people shouted, "The Lord, He is the God! The Lord, He is the God!"

God was pleased and sent rain to water the earth. The drought was ended.



## Lesson 6

# WICKED JEZEBEL

### READING ASSIGNMENT: 1 KINGS 19:1-15.

**MEMORY VERSE:** *“The Lord is my strength and my shield; my heart trusted in Him, and I am helped:...” Psalm 28:7.*

Ahab was very excited about the rain. He hurried to his palace to tell his wife, Jezebel, what had happened on Mount Carmel. Jezebel was angry that the prophets of Baal had all been killed. She was so angry that she sent a message to Elijah telling him that she was going to do something terrible to him.



**CIRCLE THE LETTER OF THE CORRECT ANSWER FOR EACH QUESTION.**

### 1. What did Jezebel say would happen to Elijah?

- a. He would be killed.
- b. He would be put in prison.
- c. He would be banished to another country.

When he heard this, Elijah ran for his life. He left his servant in Beersheba and went alone into the wilderness. He became very tired of running! He was very discouraged. He began to pray even harder.

### 2. For what did Elijah pray?

- a. That Jezebel would be killed.
- b. That more ravens would take care of him.
- c. That God would take his life.

Soon he fell asleep under a juniper tree. Suddenly someone touched him and said, "Arise and eat."

### 3. Who came to Elijah?

- a. The Lord.
- b. An angel.
- c. Jezebel.

When Elijah looked, there was a cake and a cruse of water in front of him. He ate and drank and went back to sleep. Again the angel woke him and said, "Arise and eat; because the journey is too great for thee." Elijah ate and drank and went for many days on the strength of that food.

### 4. How many days and nights did he go without eating another meal?

- a. 10
- b. 40
- c. 7

Elijah went to Mount Horeb and found a cave for shelter. God came to him and instructed him to go and stand on the mountain before the Lord.



### **PUT AN X IN FRONT OF THE THINGS THAT HAPPENED.**

- \_\_\_ A great, strong wind blew past Elijah.
- \_\_\_ A terrible rainstorm came.
- \_\_\_ An earthquake shook the earth.
- \_\_\_ Fire appeared.
- \_\_\_ It began to snow.

Still, the Lord was not in all of these things. Then a still, small voice came to Elijah. God told him that he would not take his life, because there was a lot of work left for him to do. For one thing, he was to anoint Elisha to be the prophet in his place. So, Elijah went on to do the Lord's bidding and finish his work.



## Lesson 7

# ELIJAH AND ELISHA

### READING ASSIGNMENT: 1 KINGS 19:19-21.

**MEMORY VERSE:** *“For even hereunto were ye called: because Christ also suffered for us, leaving us an example that ye should follow His steps. “ 1 Peter 2:21.*

Elisha's call to the Lord's service was very direct and simple. As Elijah was returning from the wilderness where he had been hiding, he passed by the field where Elisha was working.



### CIRCLE THE LETTER OF THE CORRECT ANSWER FOR EACH QUESTION.

- 1. What was Elisha doing when Elijah came?**
  - a. Sowing seed.
  - b. Plowing.
  - c. Reaping.
- 2. How many yoke of oxen was he working with?**
  - a. 12
  - b. 5
  - c. 1

Elisha's family must have been very wealthy, because twelve yoke of oxen were very expensive.

**3. When Elijah came near, what did he throw over Elisha's shoulders?**

- a. His blanket.
- b. His scarf.
- c. His mantle.

Elisha knew that this was an honor—that Elijah was bestowing his own office upon him. He immediately left his oxen and ran to follow Elijah.

**4. To whom did Elisha want to say good-bye?**

- a. King Ahab.
- b. His mother and father.
- c. His uncle.

Elijah then said to Elisha, "Go back again: for what have I done to thee?" Elisha returned and killed two of his oxen and prepared them for his last meal at home. They were served to the people for a feast, and then Elisha went and joined Elijah. This was the way he began his training as a prophet.



**MATCH THE WORDS IN THE LEFT COLUMN WITH THE CORRECT MEANINGS IN THE RIGHT COLUMN.**

- |            |               |
|------------|---------------|
| 1. Oxen    | a. Cloak      |
| 2. Cruse   | b. Rich       |
| 3. Mantle  | c. Cattle     |
| 4. Prophet | d. Bottle     |
| 5. Wealthy | e. Man of God |

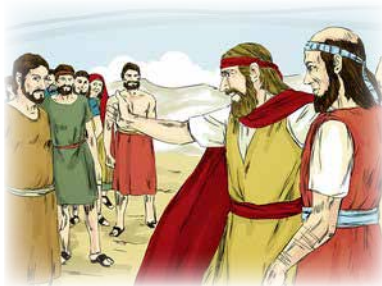



## Lesson 8

# ELISHA THE PROPHET

### READING ASSIGNMENT: 2 KINGS 2:1-11.

**MEMORY VERSE:** *“As the Lord liveth, and as thy soul liveth, I will not leave thee.” 2 Kings 2:6.*

Soon Elijah's work would be finished. He had been faithful to the Lord through persecution, affliction, and hard times. He had done everything that God asked him to do, and now it was nearly time for him to leave. Elisha stayed with him all the time, because he was preparing to take over the work when Elijah was gone.

From Gilgal, Elijah and Elisha journeyed further. Elijah told Elisha that the Lord wanted him to go to Bethel but that Elisha should remain where they were, and Elijah would go on alone.

### CIRCLE THE LETTER OF THE CORRECT ANSWER FOR EACH QUESTION.

#### 1. What was Elisha's response to this?

- a. He agreed.
- b. He insisted on going with Elijah.
- c. He wanted Elijah to stay.

So together they went to Bethel.

## 2. Who came to meet them?

- a. Sons of the prophets
- b. Obadiah
- c. Elisha's parents

They asked Elisha, "Knowest thou that the Lord will take away thy master from thy hand today?" Elisha said that he knew Elijah would soon be gone. Elijah was sent to Jericho and Jordan, and Elisha went with him.

On the bank of the Jordan River, Elijah took off his mantle, rolled it up, and struck the water with it.



### TRUE OR FALSE?

## 3. When Elijah struck the water with his mantle, the water divided, leaving dry land for him to pass over the river. T/F

After crossing over the water on dry land, Elijah asked Elisha, "Ask what I shall do for thee before I be taken away from thee."



### UNSCRAMBLE THE WORDS OF ELISHA'S ANSWER, FOUND IN 2 KINGS 2:9.

"I pray, be on me, of your spirit, let a, double portion."

As they walked and talked, the heavens were divided, and a flaming chariot with horses of fire came between Elijah and Elisha. Elijah got into the chariot, and it went up by a whirlwind into heaven.



### CIRCLE THE LETTER OF THE CORRECT ANSWER.

## 4. What did Elisha find?

- a. Elijah's mantle
- b. The chariot

Elisha picked up Elijah's mantle and struck the water, and it again divided so he could cross on dry land back to the other side. The fifty prophets who had followed saw this exclaimed, "The spirit of Elijah doth rest on Elisha!" And this was true. Now Elisha would take Elijah's place.

 ON THE MAP BELOW, DRAW A LINE SHOWING ELIJAH AND ELISHA'S JOURNEY.

- From GILGAL to BETHEL
- From BETHEL to JERICHO
- From JERICHO to JORDAN.



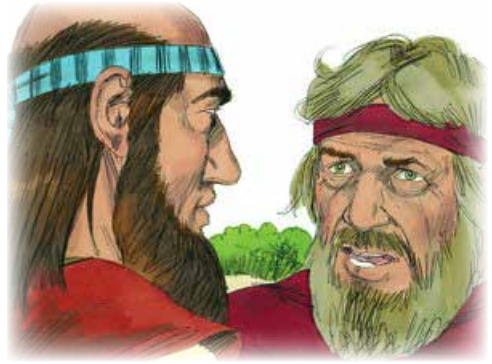

## Lesson 9

# ELISHA AND THE BAD BOYS

### **READING ASSIGNMENT: 2 KINGS 2:19-25.**

**MEMORY VERSE:** *“But they mocked the messengers of God, and despised His words, and misused His prophets, until the wrath of the Lord arose against His people,...” 2 Chronicles 36:16.*

One day the men of the city of Jericho came to Elisha with a serious problem. They did not know what to do about the water there, because it did not taste good.

### **CIRCLE THE LETTER OF THE CORRECT ANSWER.**

#### **1. What did Elisha ask the elders to bring him?**

- a. Oil
- b. Salt
- c. Dirt

He took it to the spring and poured it into the water. He said, “Thus saith the Lord, I have healed the waters; there shall not be from thence any more death or barren land. So the waters were healed unto this day,...” 2 Kings 2:21, 22. This was the first of sixteen miracles that were associated with Elisha the prophet. He then made his way back to Bethel. As he came near the city, a group of bad boys began to harass him.

### **UNSCRAMBLE THE WORDS.**

#### **2. What did the boys shout at Elisha the prophet?**

Bald go head up thou.

These young people were making fun of Elisha and telling him to go up to heaven, as Elijah had. Elisha knew that the people did not believe what he told them about Elijah's being taken to heaven. And these boys did not believe what Elisha taught, either. He knew something must be done, or the work of the Lord would suffer greatly.



**CIRCLE THE LETTER OF THE CORRECT ANSWER FOR EACH QUESTION.**

**3. What did Elisha do?**

- a. Cursed the boys in the name of the Lord.
- b. Spanked them.
- c. Prayed.

Elisha was a very kind man, but God had to deal with these disrespectful young people.

**4. When he cursed them in the name of the Lord, what came out of the woods?**

- a. She bears
- b. Snakes
- c. Woodsmen

The bears ran after the bad boys and hurt forty two of them. This seems like a terrible punishment just because the young people were making fun of Elisha. But God had to show the people that they could not be disrespectful of a man of His choosing. This is a lesson for us also. We must never make fun of others, especially if they are doing God's work.

**5. Where did Elisha go to begin his ministry?**

- a. Mount Horeb
- b. Jericho
- c. Mount Carmel



**FIND THESE WORDS IN THE WORD SEARCH PUZZLE BELOW.**

Chariot

Elijah

Jezebel

Ahab

Baal

Jordan

Obadiah

Mantle

Bethel

Jericho

Elisha





## Lesson 10

# THE WOMAN OF SHUNEM

### READING ASSIGNMENT: 2 KINGS 4:8-37.

**MEMORY VERSE:** *“And she said unto her husband. Behold now, I perceive that this is an holy man of God, which passeth by us continually.” 2 Kings 4:9.*

In his travels, Elisha often passed through a town called Shunem. In this town lived a very nice woman who often invited Elisha to come to her home and share a meal with her and her husband.

### FILL IN THE BLANKS.

#### 1. What did the woman in Shunem tell her husband about Elisha?

“I perceive \_\_\_\_\_ this is an \_\_\_\_\_ man, which \_\_\_\_\_ by us continually.” 2 Kings 4:9.

The woman decided that they should prepare a small room where Elisha could stay whenever he came to Shunem.

### PUT AN X IN FRONT OF THE THINGS THAT THE WOMAN PUT IN THE ROOM FOR ELISHA.

\_\_\_ Bed

\_\_\_ Stool

\_\_\_ Table

\_\_\_ Candlestick

\_\_\_ Pictures

\_\_\_ Mirror

Elisha was very happy to have such a nice room and to be treated so kindly by this family. He asked his servant, Gehazi, to bring the lady to him so he could thank her.

When she came, Elisha asked her what he could do to repay the kindness that she had shown to him. He offered to speak to the king or the captain of the army if she had anything to ask of them. No, she did not want anything like that. Then Gehazi thought of something. The woman had no child, and her husband was old.



**CIRCLE THE LETTER OF THE CORRECT ANSWER FOR EACH QUESTION.**

**2. What did Elisha promise the hospitable woman?**

- a. She would soon be rich.
- b. Nothing.
- c. In a year she would have a son.

The woman couldn't believe it! She thought it was impossible for Elisha's promise to come true. But a year later, she had a son. Oh, how she loved that little boy! One day when the child was older and working in the field, he became ill. He was taken to his mother, but a short time later he died.

**3. After laying her son on Elisha's bed, where did she go?**

- a. To the king.
- b. To find her husband.
- c. To find Elisha.

When Elisha heard what had happened, he gave his servant Gehazi his staff and told him to go and lay the staff upon the boy's face. But nothing happened.

Then Elisha came and went to the room, shut the door, and prayed.



**TRUE OR FALSE?**

**4. Elisha stretched himself out on the floor. T/F**

Elisha stretched himself over the boy, who got warmer; but still there was no heartbeat or breath. Elisha paced back and forth, waiting for God to work. He went back to the boy and repeated what he had done before.



**CIRCLE THE LETTER OF THE CORRECT ANSWER.**

---

**5. What happened to the boy?**

- a. He sneezed seven times and opened his eyes.
- b. He coughed and went back to sleep.
- c. Nothing.

Calling the boy's mother, Elisha said, "Take up thy son." The woman was very, very happy. She fell at the prophet's feet and poured out her gratitude.



**DRAW A PICTURE OF THE SHUNEMITE WOMAN RECEIVING HER SON BACK ALIVE.**

---

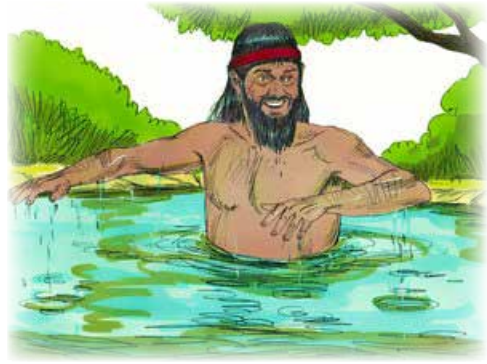

## Lesson 11

# NAAMAN'S SICKNESS

### READING ASSIGNMENT: 2 KINGS 5:1-14.

**MEMORY VERSE:** *"Wash me thoroughly from mine iniquity, and cleanse me from my sin." Psalm 51:2.*

Naaman was a great soldier and commander-in-chief of the Syrian army. He was looked upon as a brave man, and the Syrian king thought very highly of him.

In Naaman's household there lived a little Israelite servant. She was a good helper to Naaman's wife and was very careful to do her work well. She knew that Naaman had a terrible sickness called leprosy.

### CIRCLE THE LETTER OF THE CORRECT ANSWER FOR EACH QUESTION.

#### 1. **What did the little girl tell her mistress would help Naaman's sickness?**

- a. Going to see the prophet.
- b. Eating better food.
- c. Getting more rest.

Naaman's wife told him what the little girl had said, and he told the king he would like to go see the prophet. The king of Syria sent a letter with Naaman that was addressed to the king of Israel, saying that Naaman was in Israel to be cured of his leprosy. The king was very upset and tore his clothes, thinking that the Syrians were trying to start a war. He said, "Am I God, to kill and to make alive, that this man doth send unto me to recover a man of his leprosy?" But Elisha sent a message to the king to have Naaman come to his house.

**2. When Naaman arrived, what did Elisha's servant tell him to do?**

- a. Go back home.
- b. Wash in the Jordan River.
- c. Drink some medicine.

**3. How many times was Naaman to wash in the Jordan River?**

- a. 3
- b. 7
- c. 9

**4. Did Naaman obey Elisha's command immediately?**

Naaman was angry that Elisha had not come in person and performed some manifestation of power instead of sending a messenger with simple instructions. He was about to go back to his own country when one of his faithful servants persuaded him to at least try the prophet's directions. Naaman dipped under the water seven times.

**5. What happened after he went down into the water for the seventh time?**

- a. Nothing.
- b. He was a little better.
- c. He was completely healed.

Naaman returned to Elisha and said, "Behold, now I know that there is no God in all the earth, but in Israel: now, therefore I pray thee, take a blessing of thy servant." But Elisha refused the gift; he desired only that Naaman believe in and be faithful to Jehovah, the only true God.



## Lesson 12

# MIRACLE OF THE AXEHEAD

### READING ASSIGNMENT: 2 KINGS 6:1-7.

**MEMORY VERSE:** *“For with God nothing shall be impossible,...” Luke 1:37.*

Elisha was a faithful servant of God. Once when he was visiting the school of the prophets, he found out that there was not enough room for all of the students who wanted to attend. This school was important in the training of young men for the Lord's service.



**CIRCLE THE LETTER OF THE CORRECT ANSWER FOR EACH QUESTION.**

### 1. Where was this school located?

- a. Jericho
- b. Jerusalem
- c. Gilgal

### 2. What did the school leaders decide to do to make more room?

- a. Make some go home.
- b. Have them share rooms.
- c. Make a new building.

They decided to go and cut trees for the materials they needed to build the new building. They wanted Elisha to go along, so he did.

**3. What happened as one of the students was cutting trees?**

- a. The axehead fell into the water,
- b. A tree fell on Elisha.
- c. It started to rain.

**4. When the young man who was using the axe saw what had happened, he was very upset. Why?**

- a. It was new.
- b. It was the only one he had.
- c. He had borrowed it.

Elisha asked where the axehead had fallen into the water. He cut a stick and threw it toward the spot where the axehead had sunk.

**5. What happened to the axehead?**

- a. It floated.
- b. It disappeared under the water.
- c. Nothing.

The axehead was made of iron and was very heavy. It was very strange for it to float like a piece of wood. But nothing is impossible with the Lord, and He loves to help His people.



**UNSCRAMBLE THE LETTERS TO DISCOVER THE NAMES.**

JHALIE \_\_\_\_\_

MANANA \_\_\_\_\_

ZGEHIA \_\_\_\_\_

HASIEL \_\_\_\_\_



## Lesson 13

# ELISHA AND KING JOASH

### READING ASSIGNMENT: 2 KINGS 13:14-20.

**MEMORY VERSE:** *“Ye are the children of the prophets, and of the covenant which God made with our fathers,...” Acts 3:25.*

Years went by, and Elisha remained a faithful servant of the Lord. He worked very hard at every task that was set before him. The people considered him a holy man and often came to him for advice and help. After a while, Elisha became sick, and many people came to visit him.

### CIRCLE THE LETTER OF THE CORRECT ANSWER FOR EACH QUESTION.

#### 1. Who was one person who came to see the prophet?

- a. King Joash.
- b. Ahab.
- c. Gehazl.

#### 2. Who was he?

- a. A servant.
- b. King of Israel.
- c. A friend.

While they were visiting, King Joash told Elisha about the problems he was having. He was engaged in a war with the Syrians; and he was very discouraged, because things were not going well.

### **3. What did Elisha tell him to do?**

- a. Surrender to the Syrians.
- c. Fight harder.
- b. Shoot arrows eastward.

As King Joash followed the command of Elisha and shot the arrows to the east, Elisha cried, "The arrow of the Lord's deliverance, and the arrow of deliverance from Syria: for thou shalt smite the Syrians in Aphek, till thou have consumed them." 2 Kings 13:17.

Elisha was prophesying that the king would have victory in his battle. Then Elisha told the king to take the arrows and hit the ground with them.

### **4. How many times did King Joash do this?**

- a. 3
- b. 6
- c. 10

Elisha was upset, because the king did not show more energy, zeal, and enthusiasm.

### **5. How many times should he have hit the ground with the arrows?**

- a. 4
- b. 5 or 6
- c. 100 or more

If he had done so, Syria would have been completely defeated. This action would have shown the king's determination to do the work of the Lord.

Not long after this, Elisha died. The people buried him and talked of his greatness as a prophet of God. He had been faithful in all things, doing the Lord's work willingly and happily. Elisha is a good example for all of us. The Lord is glorified by all who follow Him and do His will.



**DRAW A PICTURE OF THE KING SHOOTING AN ARROW OUT THE WINDOW.**

---

# About Elisha ...



"The attention of Elijah was attracted to Elisha, the son of Shaphat, who with the servants was plowing with twelve yoke of oxen. He was educator, director, and worker. Elisha did not live in

the thickly populated cities. His father was a tiller of the soil, a farmer. Far from city and court dissipation, Elisha had received his education. He had been trained in habits of simplicity, of obedience to his parents and to God. Thus in quietude and contentment he was prepared to do the humble work of cultivating the soil. But though of a meek and quiet spirit, Elisha had no changeable character. Integrity and fidelity and the love and fear of God were his. He had the characteristics of a ruler, but with it all was the meekness of one who would serve. His mind had been exercised in the little things, to be faithful in whatsoever he should do; so that if God should call him to act more directly for Him, he would be prepared to hear his voice.

"The surroundings of Elisha's home were those of wealth; but he realized that in order to obtain an all-round education, he must be a constant worker in any work that needed to be done. He had not consented to be in any respect less informed than his father's servants. He had learned how to serve first, that he might know how to lead, instruct, and command.

"Elisha waited contentedly, doing his work with fidelity. Day by day, through practical obedience and the divine grace in which he trusted, he obtained rectitude and strength of purpose. While doing all that he possibly could in cooperating with his father in the home firm, he was doing God's service. He was learning how to cooperate with God.

"The youth should bear in mind that their physical strength, their mental qualifications, and their spiritual endowments, are to be devoted to service. These are never to be misapplied, never misused, never left to rust through inaction. Elisha increased in knowledge daily. Daily he prepared to do service in any way that opened before him. He served God in the little temporal duties. He grew in knowledge and in grace. And if the student today will develop reliability and soundness of principle in the things which are least, he will reveal that he has acquired adaptability to serve God in a higher capacity. He who feels that it is of no great consequence to serve in the lesser capacity will never be trusted of God to serve in the more honored position. He may present himself as fully competent to accomplish the duties of the higher position; but God looks deeper than the surface. A watcher is on his track, and after test and trial, there is written against him, 'Thou art weighed in the balances, and art found wanting.' That sentence in the courts of heaven decides for eternity the destiny of the human being." —*The Youth's Instructor*, April 14, 1898,